

BT SERIES | Batch Treatment Systems

Taking bigger steps to leave a smaller footprint



FEATURES & BENEFITS

- Waste Volumes 1,000 - 10,000 GPM
- Treats Complicated / Variable Wastes in Segregated Batches
- Fully Integrated Controls
- Modular, Expandable
- Versatile Programming & Automation Options
- Robust Design for Many Types of Wastes



See our web site for more details
www.macdermidenvio.com

Email: isenquiries@macdermidenvio.com

© 2020 MacDermidEnvio.

BT SERIES | Batch Treatment Systems

Flexibility & Scalability

Designed to manage a wide variety of wastes from any number of industrial applications.

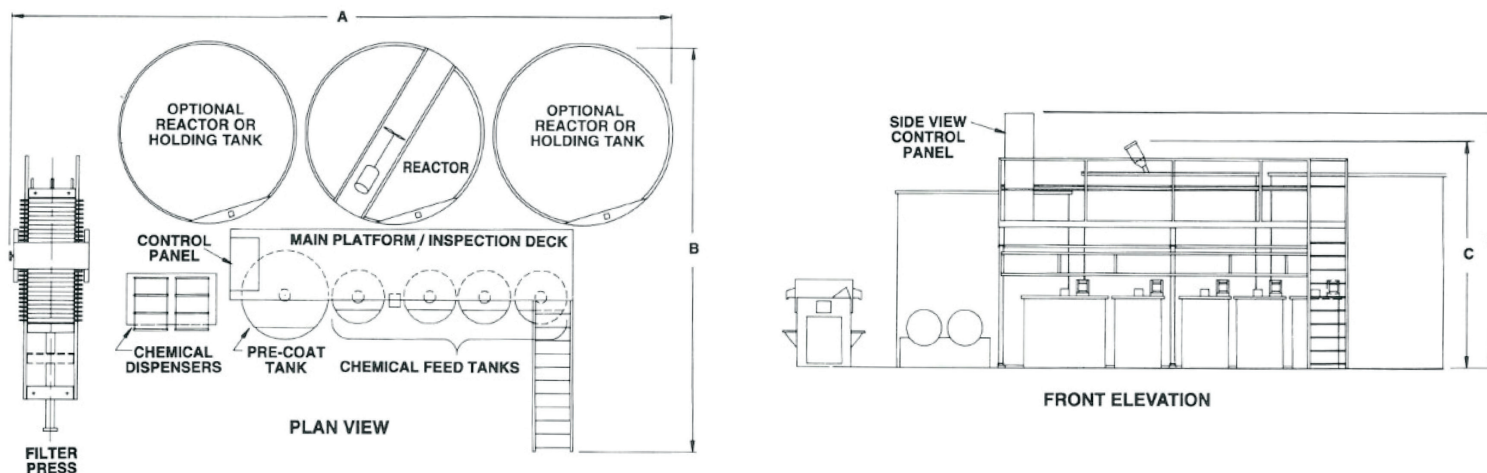

DIMENSIONAL REQUIREMENTS

	BT 1000	BT 2000	BT 3000	BT 4000	BT 5000	BT 6000	BT 8000	BT 10,000
A	21' - 7"	22' - 0"	25' - 0"	26' - 0"	39' - 0"	39' - 0"	45' - 0"	45' - 0"
B	12" - 6"	14' - 6"	15' - 6"	16' - 6"	22' - 0"	24' - 0"	25' - 6"	28' - 6"
C	11' - 0"	12' - 0"	12' - 0"	12' - 6"	13' - 0"	15' - 0"	14' - 6"	17' - 6"
D	12' - 6"	13' - 6"	13' - 6"	14' - 0"	14' - 6"	16' - 6"	16' - 0"	19' - 0"

BENEFIT

MacDermid Envio Solutions turnkey modular design approach means our systems arrive onsite pre-engineered and thoroughly tested so the time from order to production is as short as possible.

Ask us about



EnvioCARE



See our web site for more details
www.macdermidenvio.com

Email: isenquiries@macdermidenvio.com

© 2020 MacDermidEnvio.