

# MOVING BED BIOFILM REACTOR | (MBBR)

Taking bigger steps to leave a smaller footprint

Single Stage MBBR shown

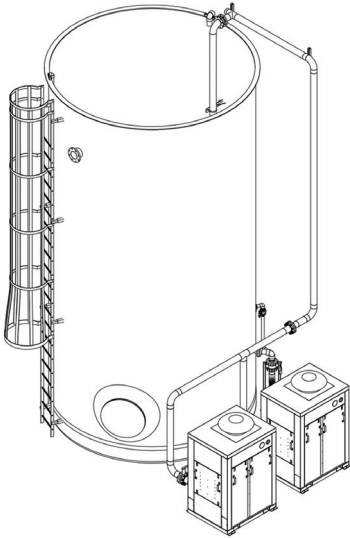

Only MacDermid Envio Solutions holistic approach to wastewater treatment ensures that your MBBR integrates into your system for the most optimal & cost-effective BOD/COD, TKN & phosphorus removal.

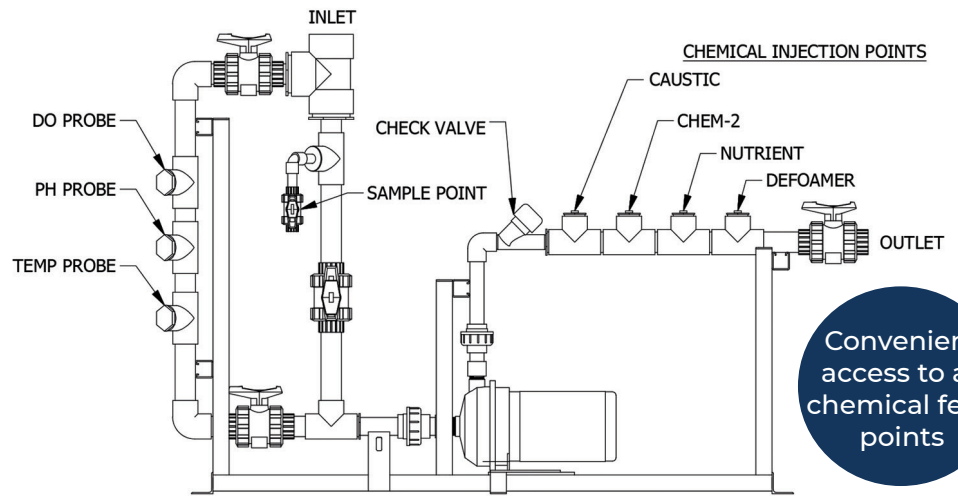

## Features & Benefits

- Self-regulating system that manages fluctuation of incoming waste
- Automated operations through optimized controls
- 100% accountability through the Performance Guarantee Program\*

\*If the system fails to meet the MacDermid Envio Solutions specifications outlined in the project, we will correct mistakes up to and including furnishing a completely new system. That's how confident we are in our ability to engineer a high-quality system the first time around. Ask a MacDermid Envio Solutions rep for full details on the Performance Guarantee Program.

Ask about our



See our web site for more details  
[www.macdermidenvio.com](http://www.macdermidenvio.com)

Email: [isenquiries@macdermidenvio.com](mailto:isenquiries@macdermidenvio.com)

© 2020 MacDermidEnvio.